

# PRODUCT SPECIFICATION

<b>Part No.:</b>	<b>AC-QF-Q1G40-30</b>	
<b>Description:</b>	40G QSFP+ Transceiver, LR4 30km	
<b>Release Date</b>	<b>Rev.</b>	<b>Revision Change Description</b>
<b>2017/06/07</b>	<b>A0</b>	New Release
<b>2020/12/28</b>	<b>A1</b>	Template Update

## Features

---

- ✧ Transmission data rate up to 11.2Gbps per channel
- ✧ Digital Diagnostics Monitoring Interface
- ✧ Hot-pluggable QSFP+ form factor
- ✧ Aggregate Bandwidth of up to 44.0G
- ✧ 4 Parallel lanes design
- ✧ Commercial operating case temperature range: 0~70°C
- ✧ RoHS-6 Compliant
- ✧ Maximum power consumption 3.5W
- ✧ Single +3.3V power supply
- ✧ Up to 30km transmission on single mode fiber (SMF)
- ✧ Duplex LC Receptacle

## Application

---

- ✧ 40GBASE-LR4 40G Ethernet links
- ✧ Infiniband QDR, DDR and SDR
- ✧ Datacenter and Enterprise networking

## Standard

---

- ✧ Compliant to IEEE 802.3ba
- ✧ Compliant with QSFP+ MSA
- ✧ Compliant to SFF-8436

## Specification:

Absolute Maximum Ratings				
Parameter	Symbol	Min	Max	Unit
Storage Ambient Temperature	T <sub>STG</sub>	-40	85	°C
Operating Humidity	H <sub>O</sub>	5	95	%
Power Supply Voltage	V <sub>CC</sub>	0	3.6	V
Damage Threshold, each Lane	THd		3.3	dBm

Recommended Operating Conditions					
Parameter	Symbol	Min	Typical	Max	Unit
Operating Case Temperature (Commercial)	T <sub>c</sub>	0		70	°C
Power Supply Voltage	V <sub>CC</sub>	3.13	3.3	3.47	V
Power Consumption	P <sub>diss</sub>			3.5	W
Signaling Speed Per Channel			10.3125	11.2	Gbps
Control Input Voltage High		2		V <sub>CC</sub>	V
Control Input Voltage Low		0		0.8	V
Fiber Length 9/125μm core SMF		-	-	30	KM

Electrical transmitter Characteristics						
Parameter	Symbol	Min	Typical	Max	Unit	Notes
Transceiver Power-on Initialization Time				2000	ms	1
Single-ended Input Voltage Tolerance (Note 2)		-0.3		4.0	V	Referred to TP1 signal common
AC Common Mode Input Voltage Tolerance			15		mV	RMS
Differential Input Voltage Swing Threshold		50			mVpp	LOSA Threshold
Differential Input Voltage Swing	V <sub>in,pp</sub>	190		700	mVpp	
Differential Input Impedance	Z <sub>in</sub>	90	100	110	Ohm	
Supply Current	I <sub>CC</sub>			1.1	A	
Maximum Power Consumption				3.5	W	
Maximum Power Consumption – LP Mode				1.5	W	
J2 Jitter Tolerance	Jt2	0.17			UI	
J9 Jitter Tolerance	Jt9	0.29			UI	
Data Dependent Pulse Width Shrinkage (DDPWS) Tolerance		0.07			UI	
Eye Mask Coordinates {X1, X2 Y1, Y2}			0.11, 0.31 95, 350		UI mV	Hit Ratio =5x10 <sup>-5</sup>

Signaling Speed Operating Range			$\pm 100$		ppm	
Transmitter Differential Input Impedance			100		ohms	
Transmitter Differential Input Voltage		0.2		1.6	V	
Electrical receiver Characteristics						
Parameter	Symbol	Min	Typical	Max	Unit	Notes
Single-ended Output Voltage		-0.3		4.0	V	Referred to signal common
AC Common Mode Output Voltage			7.5		V	RMS
Differential Output impedance			100		mVpp	
Differential output voltage		300		850	mV	
Termination Mismatch at 1MHz				5	%	
Differential Output Return Loss		See IEEE 802.3ba 86A.4.2.1			dB	10MHz - 11.1GHz
Common Mode Output Return Loss		See IEEE 802.3ba 86A.4.2.2			dB	10MHz - 11.1GHz
J2 Jitter Output	Jo2			0.42	UI	
J9 Jitter Output	Jo9			0.65	UI	
Eye Mask Coordinates {X1, X2 Y1, Y2}		0.29, 0.5 150, 425			UI mV	Hit Ratio = $5 \times 10^{-5}$

Optical transmitter Characteristics						
Parameter	Symbol	Min	Typical	Max	Unit	Notes
Data Rate Per Lane			10.3125	11.2	Gbps	
Relative Intensity Noise (RIN)				-128	dB/Hz	
Average Launch Power per lane @ TX off state				-30	dBm	
Transmitter Reflectance				-12	dB	
Optical return loss tolerance				12	dB	
Transmitter Eye Mask definition: X1,X2, X3, Y1, Y2, Y3		Compliant with 802.3ba standard {0.25, 0.4, 0.45, 0.25, 0.28, 0.4}				
Transmitter and dispersion penalty (TDP), each lane		-5.5			dB	
Average Launch Power per Lane	TxPx	-2		2.3	dBm	1
Launch Power in OMA minus TDP, each lane		-4.5		2.5	dBm	2
Difference in launch power between any two lanes (OMA)				6.5	dB	
Launch power (OMA) minus TDP per lane		-4		3.5	dBm	
Total Output Power	Pout			8.3	dBm	

Wavelength Assignment	$\lambda_0$	1264.5	1271	1277.5	nm	
	$\lambda_1$	1284.5	1291	1297.5		
	$\lambda_2$	1304.5	1311	1317.5		
	$\lambda_3$	1324.5	1331	1337.5		
Spectral Width(-20dB)	$\Delta\lambda$			1	nm	
Side Mode Suppression Ratio	SMSR	30			dB	
Extinction Ratio	ER	3.5			dB	
Transmitter Eye Mask Definition {X1, X2, X3, Y1, Y2, Y3}		{0.25, 0.4, 0.45, 0.25, 0.28, 0.4}				

### Optical receiver Characteristics

Parameter	Symbol	Min	Typical	Max	Unit	Notes
Receive Power (OMA) per Lane	RxOMA			2.5	dBm	
Average Receive Power per Lane	RXPx	-12.6		1.5		
Receiver Sensitivity (OMA) per Lane	Rxsens			-12	dBm	
Receiver Reflectance				-12	dB	
Difference in Receive Power between any two lanes (OMA)	P			7.5	dB	
Receiver Damage Threshold		3.3			dBm	3
LOS	Optical De-assert	Pd		-15	dBm	
	Optical Assert	Pa	-30			
LOS hysteresis			0.5		dB	
Receiver Electrical 3 dB upper Cutoff Frequency, each Lane	Fc			12.3	GHz	

Notes:

- 1.The maximum transmitter average optical power of 1.5 dBm is well within the guardband of receiver overload specifications of commercially available 10GBASE-LR SFP+ transceivers offered by LONTE.
- 2.Even if the TDP < 1 dB, the OMA min must exceed the minimum value specified here.
- 3.The receiver shall be able to tolerate, without damage, continuous exposure to a modulated optical input signal having this power level on one lane. The receiver does not have to operate correctly at this input power.

## Pin Definition

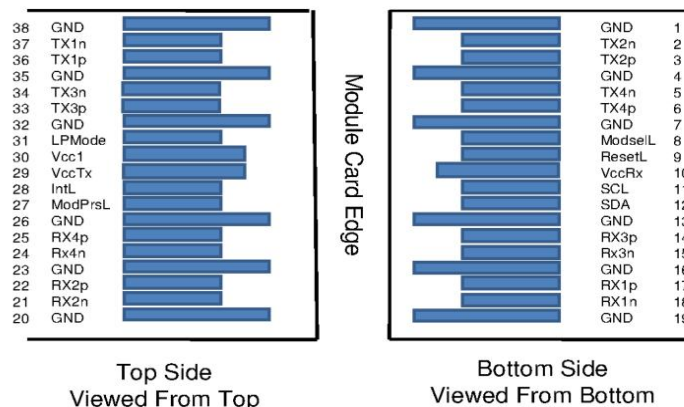

Figure1 QSFP MSA-compliant 38-pin connector

Pin	Symbol	Name/Description	Notes
1	GND	Transmitter Ground (Common with Receiver Ground)	1
2	TX2N	Transmitter Inverted Data Input	
3	TX2P	Transmitter Non-Inverted Data Input	
4	GND	Ground	1
5	TX4N	Transmitter Inverted Data Input	
6	TX4P	Transmitter Non-Inverted Data Input	
7	GND	Ground	1
8	ModSelL	Module Select	
9	ResetL	Module Reset	
10	Vcc Rx	+3.3 V Power supply receiver	2
11	SCL	2-wire serial interface clock	
12	SDA	2-wire serial interface data	
13	GND	Ground	
14	RX3P	Transmitter Inverted Data Input	
15	RX3N	Transmitter Non-Inverted Data Input	
16	GND	Ground	1
17	RX1P	Transmitter Inverted Data Input	
18	RX1N	Transmitter Non-Inverted Data Input	
19	GND	Ground	1
20	GND	Ground	1
21	RX2N	Transmitter Inverted Data Input	
22	RX2P	Transmitter Non-Inverted Data Input	
23	GND	Ground	1
24	RX4N	Transmitter Inverted Data Input	1
25	RX4P	Transmitter Non-Inverted Data Input	
26	GND	Ground	1
27	ModPrsL	Module Present	
28	IntL	Interrupt	
29	Vcc Tx	+3.3 V Power supply transmitter	2
30	Vcc1	+3.3 V Power Supply	2
31	LPMode	Low Power Mode	
32	GND	Ground	1
33	TX3P	Transmitter Inverted Data Input	
34	TX3N	Transmitter Non-Inverted Data Input	
35	GND	Ground	1
36	TX1P	Transmitter Inverted Data Input	
37	TX1N	Transmitter Non-Inverted Data Input	

38	GND	Ground	1
----	-----	--------	---

**Table 1: QSFP Module PIN Definition**

**Notes:**

1. GND is the symbol for signal and supply (power) common for QSFP+ modules. All are common within the QSFP+ module and all module voltages are referenced to this potential unless otherwise noted. Connect these directly to the host board signal common ground plane.
2. VccRx, Vcc1 and VccTx are the receiving and transmission power suppliers and shall be applied concurrently. Recommended host board power supply filtering is shown in Figure 3 below. Vcc Rx, Vcc1 and Vcc Tx may be internally connected within the QSFP+ transceiver module in any combination. The connector pins are each rated for a maximum current of 500mA.

**Package Outline**

Dimensions are in millimeters. All dimensions are  $\pm 0.2\text{mm}$  unless otherwise specified. (Unit: mm)

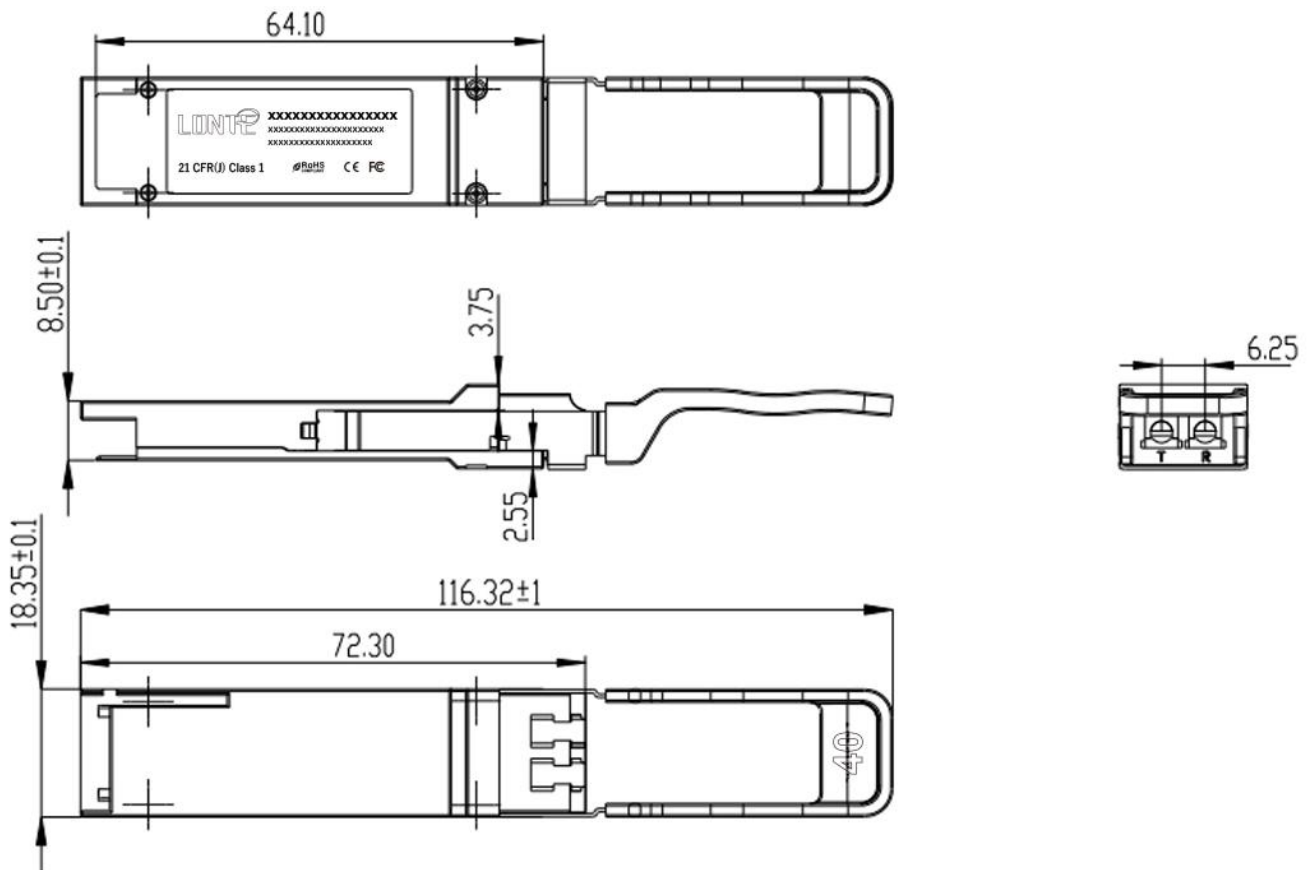

## Regulatory Compliance

Feature	Test	Method
Electrostatic Discharge (ESD) to the Electrical Pins	MIL-STD-883E Method 3015.7	Class 1(>1000V for SFI pins, >2000Vfor other pins.)
Electrostatic Discharge (ESD) Immunity	IEC61000-4-2	Class 2(>4.0kV)
Electromagnetic Interference (EMI)	CISPR22 ITE Class B FCC Class B CENELEC EN55022 VCCI Class 1	Comply with standard
Immunity	IEC61000-4-3	Comply with standard
Eye Safety	FDA 21CFR 1040.10 and 1040.11 EN (IEC) 60825-1,2	Compatible with Class I laser Product

## Ordering information

Part. No	Specifications								
	Pack	Rate (Gbps)	Tx (nm)	Po (dBm)	RX	Sen (dBm)	Temp (°C)	Reach (km)	DDM
AC-QF-Q1G40-30	QSFP+	41.25G	DFB CWDM	-2.0~2.3	PIN	<-12.0	0~70	30	Y